

DJ330 TECHNICAL SPECIFICATIONS



UNIT DETAILS

Maximum Rec. Power Continuous:	Up to 2750skW (3685shp)
Maximum Rec. Power Sprint:	Up to 3090skW (4145shp) <small>REFER NOTE: A</small>
Maximum Rec Impeller speed:	1020rpm
Dry Weight:	3250 kg (complete waterjet including jet mounted hydraulic items)
Entrained Water:	1060 kg
Loss of buoyancy	1.220 m ³ (duct volume within hull bound)
Corrosion Protection:	Cathodic with Anodes
Design Standard:	To international authority standards

CONSTRUCTION DETAILS

Impeller:

Diameter:	33 inch (838mm)
No of Stages/Configuration:	Single Stage – Axial pump construction
Standard Rotation:	Anti-clockwise (Looking forward from stern)
Impeller Material:	Cast CF8M Stainless Steel

Pump Assembly:

Impeller Casing Material:	AISI 316 Stainless Steel
Discharge Nozzle Material	Cast CF8M & AISI 316 Stainless Steel

Steering System:

Description	Balanced nozzle
Operation	Hydraulic with Dual Inboard cylinder actuation
Steering Bowl/Nozzle Material:	Cast ASTM A356 Aluminium Alloy

Reverse System:

Description	Split Duct Type – “High Thrust”
Operation	Hydraulic with Dual Inboard cylinder actuation
Reverse duct material	Cast ASTM A356 & 5083 grade plate aluminium

Shaft Assembly:

Main Shaft Material:	Stainless Steel Grade SAF 2205
Rear Bearing:	Water Lubricated Cutlass Bearing
Main Bearing:	Spherical roller Thrust Bearing
	Spherical roller Bearing - Radial
Lubrication	Oil lubrication with circulating pump
Shaft Seal:	Face type Mechanical Seal
Coupling Flange:	GWB Series to suit application
Shaft Angle	0 degrees standard – Custom shaft angles available

Intake Body:

Material:	5083 grade plate aluminium
Inspection Opening:	Inboard
Intake Grate:	Optional

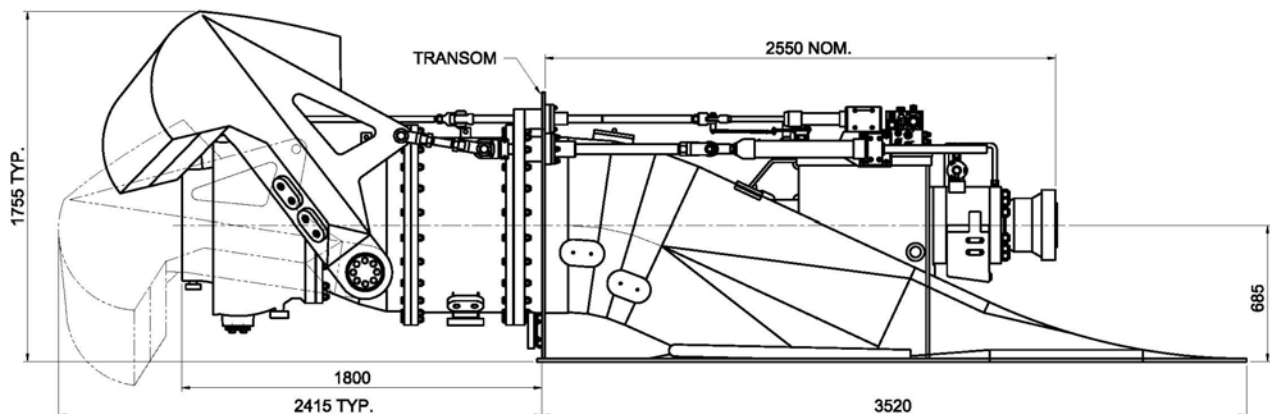

Note (A): Requires application approval by DOEN Pacific.

Due to our policy of continuous Research & Development, we reserve the right to change the specifications without notice

ISSUED 27/03/2015

T:\SALES DOCUMENTATION\Tech Specs\MASTER\DJ330 Tech spec 270315.doc